

Sports Pad Football™

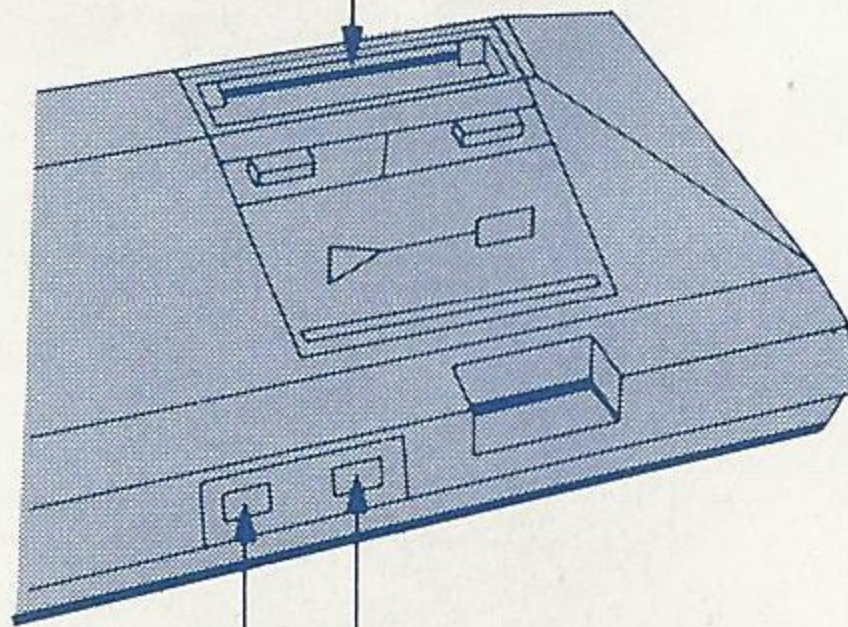

SEGA®

Insert Cartridge



Insert Sports Pad 1

Insert Sports Pad 2

Loading Instructions: Starting Up

SPORTS PAD FOOTBALL™ is designed for use with your Sega Sports Pad and will grant you the ultimate in control and experience. Because it is designed for advance playing, there are some simple instructions to follow for game setup.

How to Operate the Sega Sports Pads and Power Base:

1. Make sure the power switch is OFF.
2. Remove the control pads from the SEGA SYSTEM™ and replace them with one or two Sega Sports Pads depending on the number of players.
3. Set the controller switch on your Sega Sports Pad to "Sports" (right) and adjust the action switch to the 'one-dot' setting (left).
4. Insert the SPORTS PAD FOOTBALL™ CARTRIDGE in the power base (shown below) by following instructions in your SEGA SYSTEM™ manual.
5. Turn the power switch ON. If nothing appears on screen, recheck insertion.

IMPORTANT: Always make sure the power base is turned OFF when inserting or removing your Sega Card/Cartridge.

For 1 Player: Press Button 1 on player 1 sports pad.

For 2 Players: Press Button 2 on player 2 sports pad.

The Big Game

SPORTS PAD FOOTBALL™ is nonstop action on any yard line and because its play follows real football play so closely, you'll think the NFL has found a new home: your living room.

So go for the gusto, because there's no move too sophisticated for this game to handle since it's equipped with superior Sega Sports Pad action.

Play for the conversion with confidence, kick a field goal with accuracy and tackle any tight end with force; because now, you have the speed and agility to be a winner.

Now Make Your Move.

Before you begin playing, orient yourself with the movements and functions each button is geared to prompt. These executions should get you started on the road to victory.

Elementary Functions:

The following illustration shows you the control points on your Sega Sports Pad. And the information will guide you through all possible executions.

Ball Controller (B-Controller):

- Moves players about the field
- Will establish the passing direction of the football.

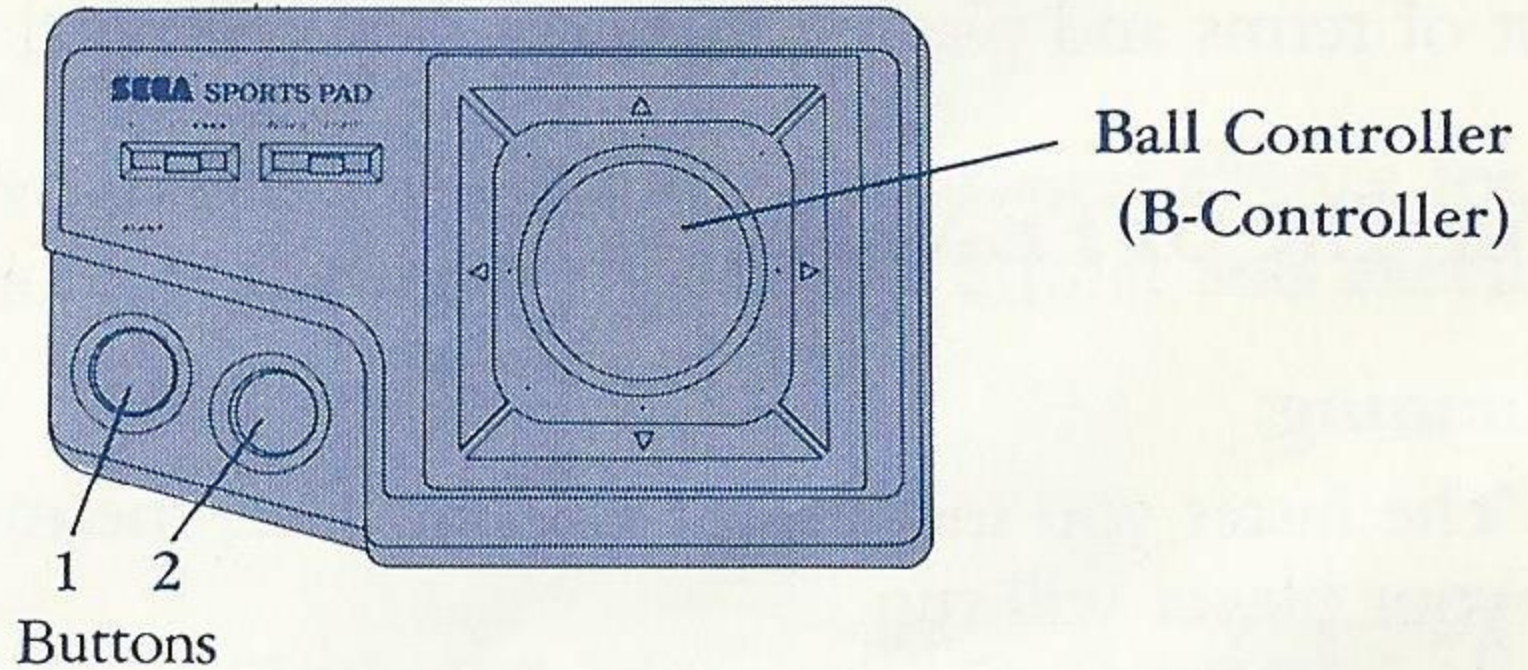

Button 1:

- Tackle
- Scramble
- Team selection
- League selection
- Start the game

Button 2:

- Tackle
- Pass
- Kick field goal
- Punt
- Block: Punt and Field goal
- Interception
- Formation pattern selection
- Team selection
- League selection
- Start the game

As you noticed, there are certain moves which both buttons can prompt, i.e. tackle. But there is a formula. Naturally, each button executes its own series of moves, but during DEFENSE, there is an overlap. And only during DEFENSE, will Button 1 and 2 prompt the same move.

Play By Play

During SPORTS PAD FOOTBALL™, you'll find the plays almost identical to professional football. So, the following is a list of terms and playing instructions you'll need to master.

For The OFFENSE:

Running:

- The faster you move your B-Controller, the more quickly your player will run.

Passing:

- Move the B-Controller in the direction you want to pass and then, press Button 2.

Scrambling:

- When you want to switch your offense from passing to running, press Button 1.

Field goal:

- If the point of offense is beyond the opponent's 45-yard line, you can select this format and execute the kick while simultaneously moving B-Controller in your desired direction and pressing Button 2.

Punt:

- If the point of offense is not beyond the opponent's 45-yard line, you can select this format and execute the punt by simultaneously moving the B-Controller in your desired direction and pressing Button 2.

Touchdown:

- When the offender with the ball makes it past the opponent's end zone; or when he completes a pass in the end zone, a touchdown is awarded.

Conversion:

- Once you've scored a touchdown, this is your chance for the extra point. Choose an appropriate format and execute any one of the plays available to you.

Offense:

- The offensive team has the 1st-4th downs to advance 10 yards, or the ball is given to the opponent.

Offense Break Off:

- The game will proceed to the next down when the player is tackled by the defender or when the pass is incomplete.

Formation:

- You can select a formation before each down. A formation is a pattern of the offensive play directions. Select according to your specific situation.
- When the formation you want flashes, press Button 2. Now, during a two-player game, the formations will continue flashing so your opponent doesn't know what you've chosen.
- During a one-player game, the pattern #9 is only for the field goal; therefore, this option can only be selected when the player is beyond the 45-yard line and takes the offensive.

Formations 1 - 4: PASSING FORMATIONS

Formations 5 - 8: RUSHING FORMATIONS

Formation 9: PUNT/FIELD GOAL

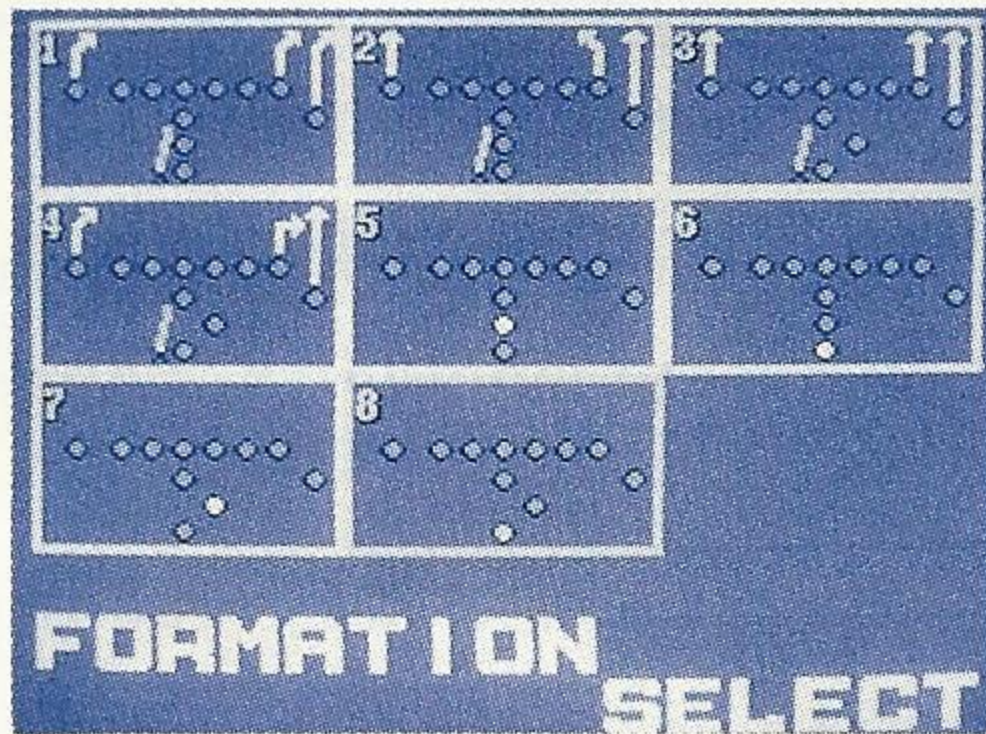

For the DEFENSE:

Tackling:

- Move your player with the B-Controller next to the opponent and press Button 1 or 2.

Interception:

- To intercept a pass, move your player into position with the B-Controller close to the receiver and press Button 2.*

*** This play follows the same execution as a tackle, but the computer will prompt an interception instead, when you are in a good position for it.**

Block:

- To block a Punt or Field goal, wait for the ball to be released and then press Button 2 for your players to converge.

Safety:

- If the offense brings the ball into his own end zone and the defense is able to gain control of the ball, then the defense earns two-points.

Know The Score

Scoring is the same as real football. Points are awarded as follows:

TOUCHDOWN	6 points
CONVERSION	1 points
FIELD GOAL	3 points
SAFETY	2 points

Rules and Regulations

SPORTS PAD FOOTBALL™ is simple to understand because the game is based on actual football standards. In order to follow these rules, know who is in your control.

- When on OFFENSE: you control the player(s) with the football.
- When on DEFENSE: you control the player(s) with bright arrows overhead.

During game play, watch the clock because timing is essential.

- There are four quarters to each game, and each quarter takes 15 minutes. (Sega clock runs three times faster than real time.)

- After the second quarter, there will be a Half-Time Show on screen.

One-Player Game:

The key to playing this game is concentrating on the offense because you won't need any defensive moves. But first pick your league and your opponent's.

- After you press your start button, you'll see the flickering flags of each conference: AFC and NFC.

AFC
Spartans
Dukes
Sharks
Bombers
Foxes
Huskies

NFC
Bucks
Wildcats
Boomers
Knights
Beavers
Gators

- This same list will be displayed during a two-player game. First, choose your league.



- Use your B-Controller to select, and press Button 2. Now, repeat the same procedure to select your team which you'll see screened like above.
- The flag of your choice will turn red. And after you've repeated this entire procedure for your opponent, their flag will be blue.
- Now, the football field will appear on screen: the game starts with the Central Processing Unit's kick off.
- Central Processing Unit (CPU) is the computer which you play against in one-player competition.
- The CPU team is ahead by a few points. Your objective during this game is to beat the opponent's score.
- You're always on the offense in this game, so the CPU team will kick off after every touchdown.

Two-Player Game:

The key to playing this game is sizing up the competition, since you're playing with a partner. This requires both offense and defense skills and it's a race for winning touchdowns.

- You and your opponent will have the opportunity to select your own league and team per the same instructions as a one-player game.
- Player #1 will select his league and team with the B-Controller and Button 1.

- Player #2 will select a team from the other league and its' teame with the B-Controller and Button 2.
- Player #1 will have red players and Player #2 will have blue players.
- After you've both selected, the screen will display the football field and the game will start with Player #2's kickoff. This happens on the 35-yard line.
- After a touchdown, the scoring team will kickoff.

Game Over:

The game is over for both one-player and two-player games when time runs out.

Winning Decision:

You'll be the winner in a one-player game if you've scored higher than the CPU team.

The winner in a two-player game is the highest scorer by the end of the game.

Referee Call:

During the game, there are no fouls and penalties, but the play decisions will be called by the referee and flashed on the screen.

- Side Change / Time Out
- Touchdown
- Safety / Conversion
- Pass Incomplete
- Kickoff / Interception

The Final Word

The game is more exciting to play when you get used to the timing of certain plays and your players' abilities. Here's a few hints.

- Practice the B-Controller's smooth movements so you can move your player effortlessly and quickly.
- For accurate passes, timing is essential. So pay attention to when you're connecting and you will be able to establish a pattern.
- Formation patterns are your winning edge. It's important to understand when to choose one over the other, so study them well.
- Remember to play aggressively, since you can't be fouled or penalized.

Handling The Mega Cartridge™

- The Mega Cartridge is intended exclusively for the Sega System™.
- Do not bend, crush or submerge in liquids.
- Do not leave in direct sunlight or near a radiator or other source of heat.

Scorebook

Date		
Name		
Score	—	

Date		
Name		
Score	—	

Date		
Name		
Score	—	

Date		
Name		
Score	—	

Date		
Name		
Score	—	

Date		
Name		
Score	—	

90-Day Limited Warranty

Sega® Card/Cartridge

To validate the following 90-day limited warranty, your sales slip or proof of purchase should be retained at time of purchase and presented at time of warranty claim.

90-Day Limited Warranty

Sega of America, Inc. warrants to the original consumer purchaser that this Sega Card™/Cartridge™ shall be free from defects in material and workmanship for a period of 90 days from the date of purchase. If defect covered by this warranty occurs during this 90-day warranty period, Sega will repair or replace the defective card/cartridge, at its option, free of charge.

This warranty does not apply if the defects have been caused by negligence, accident, unreasonable use, modification, tampering or any other causes not related to defective materials or workmanship.

To receive fast, reliable service, call the Sega Customer Service Department at the following numbers:

Outside California: 800-USA-SEGA

Inside California: 415-742-9300

Our Customer Service Department is in operation from 9:00 AM to 5:00 PM (Pacific Time), Monday through Friday. *Do not return your Sega Card/Cartridge to your retail seller.*

Sega's service center is located at the following address:

Sega of America, Inc.

Warranty Repair

573 Forbes Blvd.

South San Francisco, CA 94080

Limitations On Warranty

Any applicable implied warranties, including warranties of merchantability and fitness for a particular purpose, are hereby limited to ninety days from the date of purchase and are subject to the conditions set forth herein. In no event shall Sega of America, Inc. be liable for consequential or incidental damages resulting from the breach of any express or implied warranties.

The provisions of this warranty are valid in the United States only. Some states do not allow limitations on how long an implied warranty lasts or exclusion of consequential or incidental damages, so the above limitations of exclusion may not apply to you. This warranty provides you with specific legal rights. You may have other rights which vary from state to state.

Now, there are no limits.[®]

SEGA[®]

SEGA OF AMERICA, INC., 573 Forbes Blvd., South San Francisco, CA 94080, (415) 742-9300

A CSK GROUP COMPANY

Printed in Japan

© 1987 SEGA OF AMERICA, INC.